

MODEL NUMBER	IEEE30-18-286T		
HORSEPOWER	30		
RPM / POLES	1800 / 4		
VOLTAGE / PHASE	460 / 3		
FRAME	286T		
ENCLOSURE / DEGREE OF PROTECTION	TEFC / IP56		
FREQUENCY	60 HZ		
FULL LOAD SPEED	1775 RPM		
SERVICE FACTOR	1.15		
INSULATION CLASS	F Class N Varnish		
FULL LOAD AMPS; 460	36.0 A		
LOCKED ROTOR CURRENT (% Full Load)	680 %		
NEMA CODE LETTER	H		
EFFICIENCY / POWER FACTOR	<u>LOAD</u>	<u>EFF.</u>	<u>P.F.</u>
	100 %	93.6 %	82.0 %
	75 %	93.8 %	79.5 %
	50 %	93.0 %	73.0 %
DUTY CYCLE	S1 / Continuous		
TORQUE	<u>FULL LOAD</u>	<u>LRT</u>	<u>BDT</u>
	87.3 lb.ft	170 %	220 %
NEMA DESIGN	B		
MOMENT OF INERTIA	<u>LOAD (Max.)</u>	<u>MOTOR</u>	
	397.486 lb.ft <sup>2</sup>	5.578 lb.ft <sup>2</sup>	
SOUND PRESSURE LEVEL ( No Load 1 M From Motor)	77 dB(A)		
MAX. SHAFT VIBRATION	0.08 In/Sec – Peak Velocity		
NUMBER OF STARTS (Hot / Cold)	2 Hot / 3 Cold		
MAX. AMBIENT TEMPERATURE	40° C		
MAX. ELEVATION	3300 Ft. Above Sea Level		
TEMPERATURE RISE (At Full Load)	80° C		
DRIVE-END BEARING	6310ZC3		
OPPOSITE DRIVE-END BEARING	6310ZC3		
BEARING SEAL TYPE	ProTech™ IP66 Labyrinth On DE and ODE		
GREASE TYPE	Mobil Polyrex EM		
MOUNTING	F1 (F2 Suitable), W6, W8, B3, V5, V6		
ROTATION	Bi-Directional		
APPROXIMATE WEIGHT	410 lbs		
AREA CLASSIFICATION	Class I, Division 2, Groups A, B, C, D, T3A		
PAINT	Epoxy		
INVERTER RATING	10:1 CT / 1000:1 VT		
INSULATION TYPE	Hyundai Inverter Shield, Meets NEMA MG1 Part 31		
SPECIFICATION - In Accordance With	IEEE-841, Version 2009, NEMA, CSA		



CC 038A





# IEEE841 TEFC

**THREE PHASE INDUCTION MOTOR**

**TYPE**

PLP

CAST IRON FRAME

FRAME SIZE

OUTPUT(HP)

POLES

Hz

TIME RATING

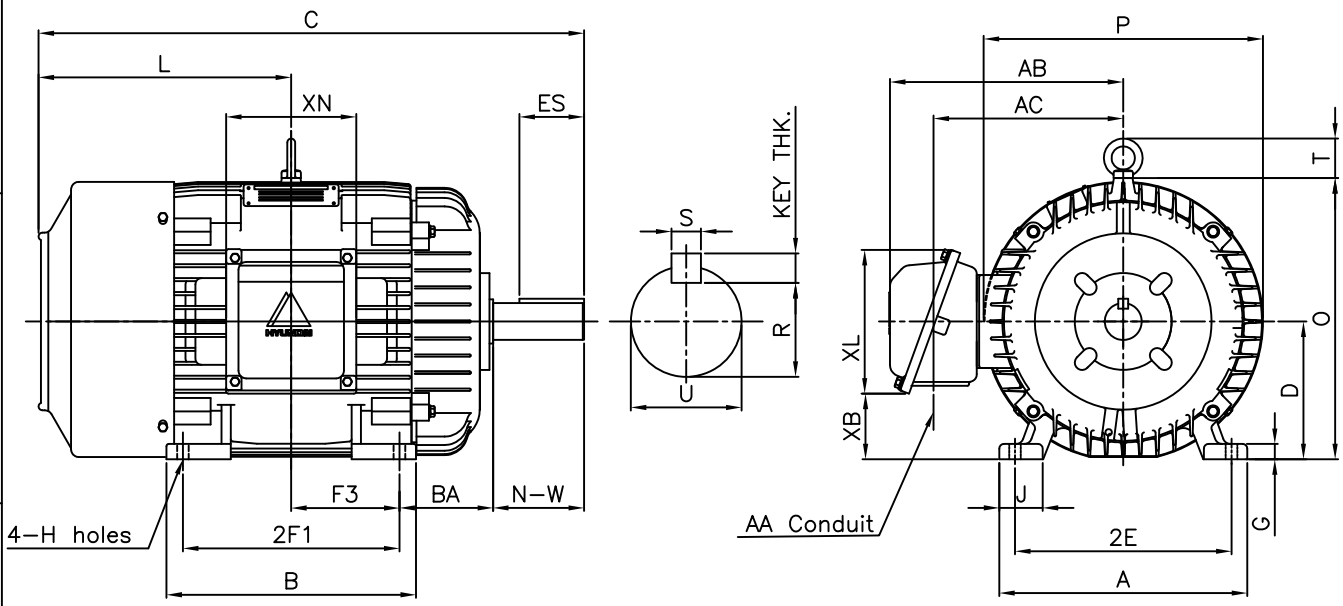

## DIMENSIONS

M O U N T I N G									C O N D U I T B O X						APPROX. WGT.(LB)
A	B	2E	2F1	2F2	F3	G	J	H	AA	AB	AC	XB	XL	XN	286T
12.60	12.68	11.00	11.00	-	5.50	0.78	2.20	0.53	1.50	12.43	9.64	3.42	7.56	6.61	410

O V E R A L L							S H A F T					KEY THK.	B E A R I N G	
BA	C	D	L	O	P	T	U	N-W	KEYWAY				DRIVE END	OPP. DRIVE END
									R	ES	S			
4.75	26.28	7.00	12.16	14.28	14.19	2.01	1.875	4.62	1.591	3.28	0.500	0.500	6310ZC3	6310ZC3

**NOTE**

- 1.Dimension "D" tolerance : +0.00inch - 0.03inch
- 2.Dimension "U" tolerance : +0.000inch - 0.001inch
- 3.Dimension "R" tolerance : +0.000inch - 0.015inch

APPD BY	J. H. KIM	UNIT	INCH	SUBJECT	NEMA 286T	CAD PROJ \ FILE	XSMOUTN\A8110AA
CHKD BY	K. S. LEE	SCALE	1/10				
CHKD BY		PROJEC'N	3rd Angle	TITLE			
DSND BY	KIM IN KYU	DATE	2010.12.31				

## OUTLINE

	REF. NO	A1110AA	Sheet No.	of
	DWG NO	350A8110AA	Revision No.	0

Type	:	PLP
Full Load Torque	:	87.3 lb.ft
Motor moment of Inertia (J)	:	5.578 lb.ft <sup>2</sup>
Load moment of Inertia (J)	:	397.486 lb.ft <sup>2</sup>

22 kW	30 HP	60 Hz	
4 P	Rated Speed : 1775 RPM		
Rated Voltage	575V	460V	230V
Full Load Current	28.8A	36.0A	72.0A

SPEED VS TORQUE & CURRENT CURVE

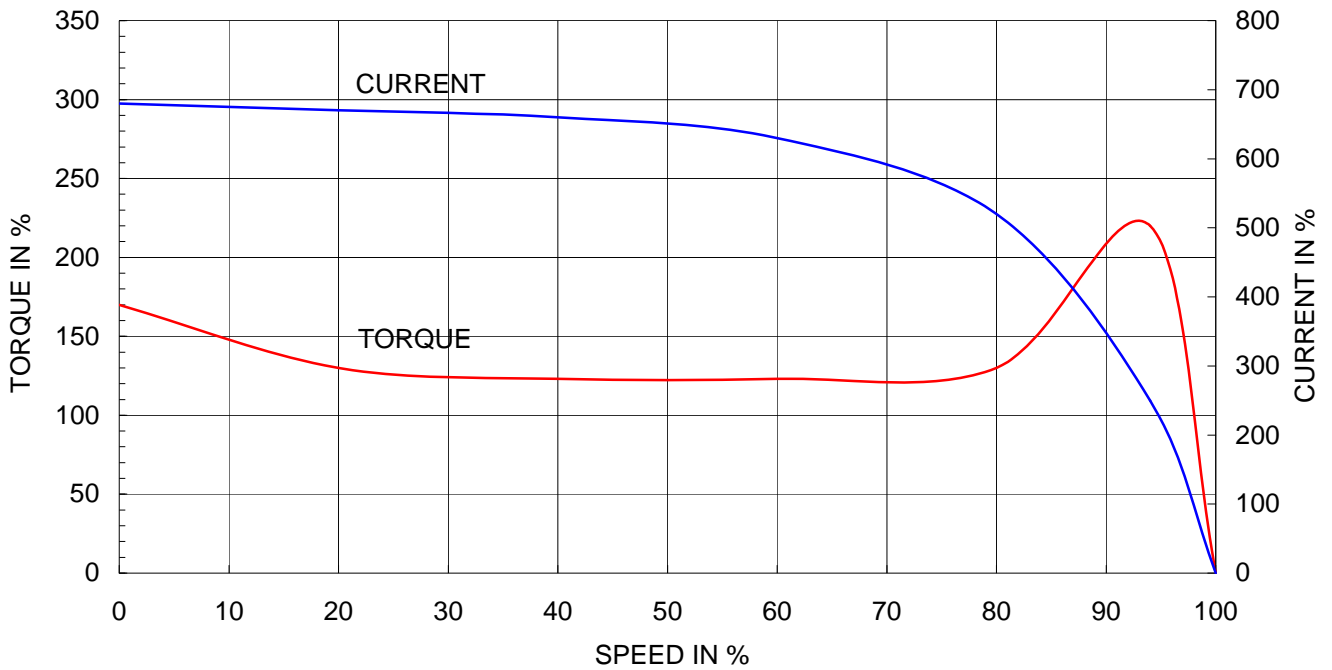

OUTPUT VS EFF., P.F & CURRENT CURVE

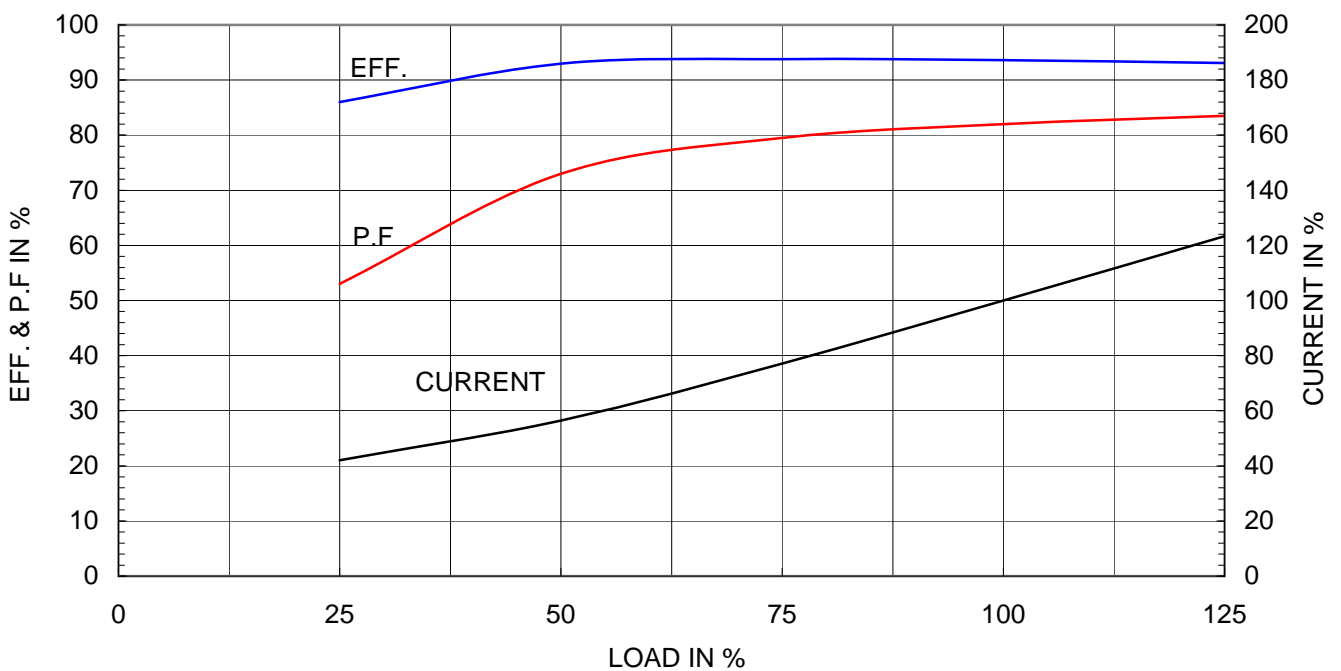



THERMAL LIMIT & TIME CURRENT CURVE

CURVE NO.

T-PLP30-18-286T

Type :	PLP30-18-286T		30	HP	4	P	60	Hz
FULL LOAD TORQUE :	87.3	lb.ft	RATED SPEED :		1775 rpm			
J OF LOAD :	-	lb.ft <sup>2</sup>	VOLTAGE		460 V	575 V		
J OF MOTOR :	5.6	lb.ft <sup>2</sup>	RATED CURRENT		36.0A	28.8A		

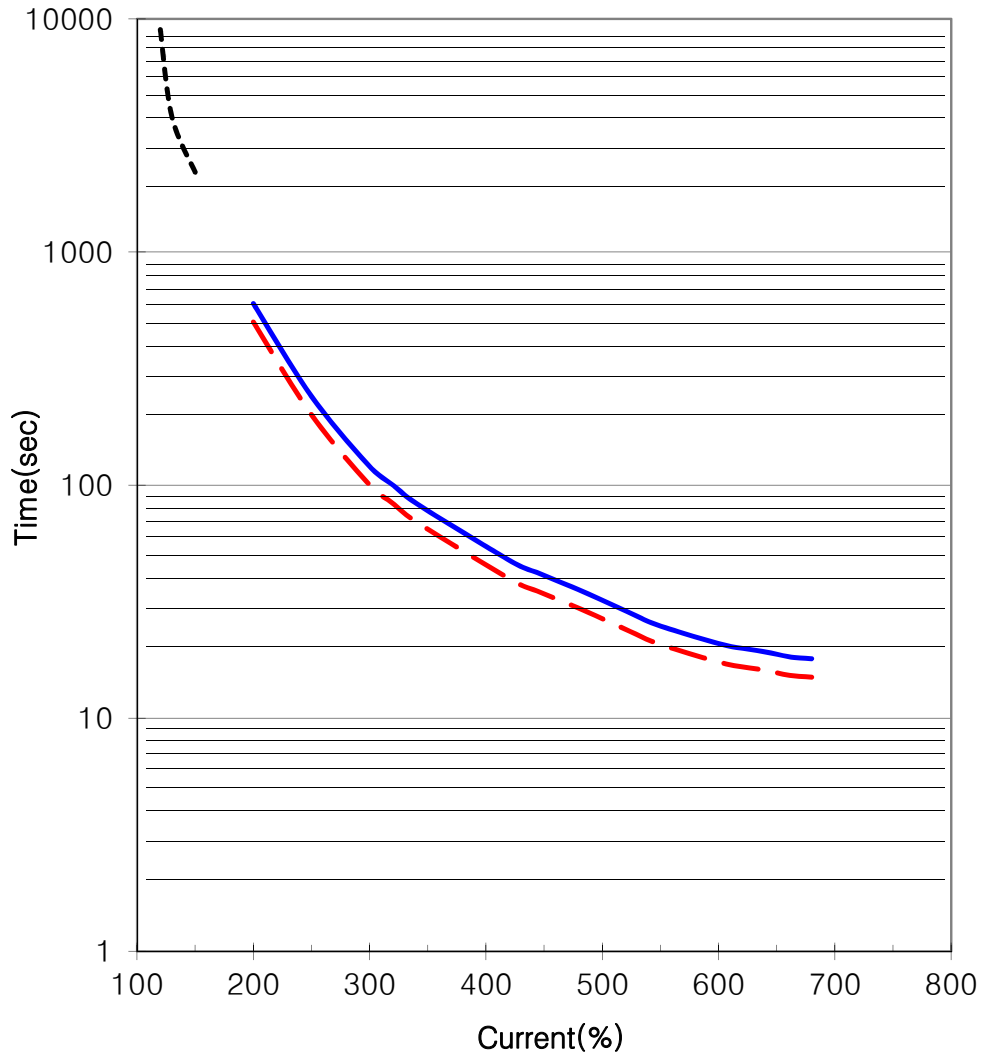

— THERMAL LIMIT CURVE AT COLD CONDITION  
- - - THERMAL LIMIT CURVE AT HOT CONDITION

STARTING TIME	SAFE STALL TIME
- at rated voltage starting	15 sec. at Hot condition
- at 80% of rated voltage starting	18 sec. at Cold condition

THIS DRAWING IS PROPRIETARY TO HHI. NO PART OF THIS DRAWING MAYBE REPRODUCED WITHOUT THE PERMISSION OF HHI.

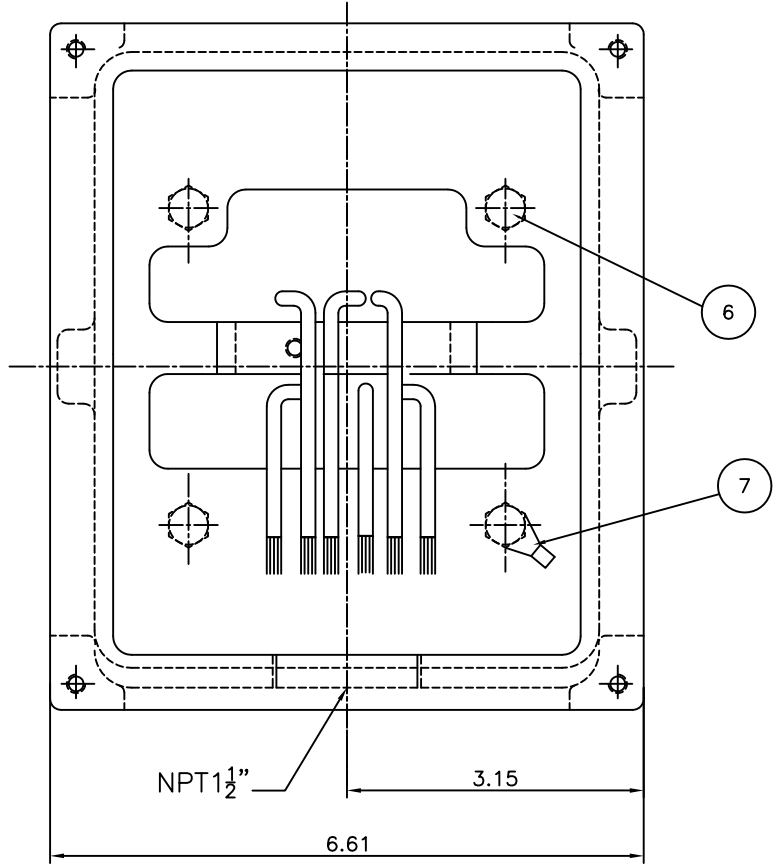
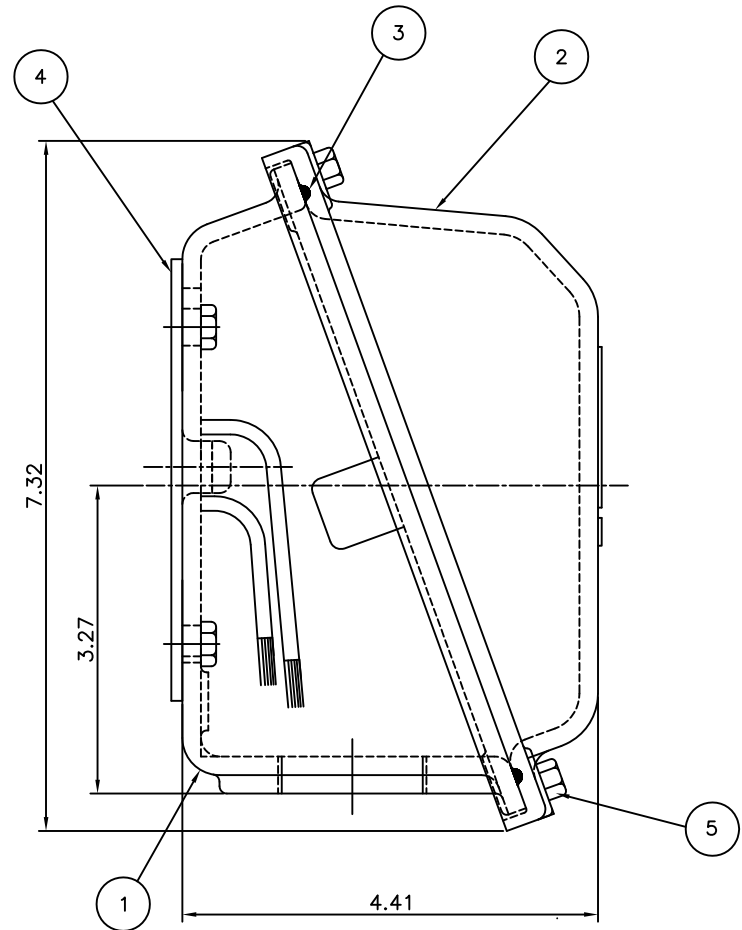

PT	DESCRIPTION	MATERIAL	DIMENSION	Q'TY
1	CONDUIT BOX	FC15	--	1
2	CONDUIT BOX COVER	FC15	--	1
3	O-RING / COVER	EPDM	φ4	1
4	BOX GASKET	NBR	--	1
5	COVER+BOX HEX BOLT	S45C	M6 X L20	4
6	BOX+FRAME HEX BOLT	S45C	M8 X L20	4
7	GROUND TERMINAL LUG	CU	--	1

Q'TY	DESCRIPTION	MATERIAL	DIMENSION	WEIGHT	PART NO.	REMARK	NO.
APPD BY	KIM.Y.S	UNIT	INCH	SUBJECT	NEMA284/286	CAD PROJ FILE	
CHKD BY	KO.S.H	SCALE	1:1	227B8008NA1			
CHKD BY	---	PROJEC'N	3각법(3rd Angle)	TITLE			
DSND BY	Y.J.HWANG	DATE	2005.02.16	TERMINAL BOX ASSEMBLY			
REF. NO		227B8008NA2		Sheet No.		of	
DWG NO		227B8008NA2		Revision No.		0	



REV	DATE	CONTENTS	REVD BY	CHKD BY	CHKD BY	APPD BY
1						
2						
3						
4						